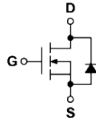

LFPAK56

Symbol

Parameter	Value	Unit
V_{DS}	40	V
$R_{DS(ON)-Max}$	0.8	m Ω
I_D	259	A

Key Features

- Fast switching speed
- Reliable and Rugged
- ROHS Compliant & Halogen-Free
- 100% UIS and Rg Tested
- AEC-Q101 qualified

Applications

- DC-to-DC converters
- Switch Mode Power Supply
- Brushless DC motor control

Ordering Information

Ordering part Number	Marking code	Package	Form
VPLMDF7147	7147	LFPAK56	Tape & Reel

Absolute Maximum Ratings ($T_j = 25^\circ\text{C}$, unless otherwise specified)

Parameter	Symbol	Rating	Unit	
Drain-Source Voltage	V_{DS}	40	V	
Gate-Source Voltage	V_{GS}	± 20	V	
Maximum Junction Temperature	T_J	175	$^\circ\text{C}$	
Storage Temperature Range	T_{STG}	-55 to 175	$^\circ\text{C}$	
Diode Continuous Forward Current	I_S	81	A	
Diode Pulse Current	I_{SP}	400 ⁽¹⁾	A	
Pulse Drain Current Tested	I_{DM}	646 ⁽¹⁾	A	
Continuous Drain Current	I_D	$T_C=25^\circ\text{C}$	259	A
		$T_C=100^\circ\text{C}$	183	
Maximum Power Dissipation	P_D	$T_C=25^\circ\text{C}$	125	W
		$T_C=100^\circ\text{C}$	63	
Continuous Drain Current	I_D	$T_A=25^\circ\text{C}$	42	A
		$T_A=70^\circ\text{C}$	35	
Maximum Power Dissipation	P_D	$T_A=25^\circ\text{C}$	3.3	W
		$T_A=70^\circ\text{C}$	1.8	
Avalanche Current, Single pulse	$I_{AS}^{(2)}$	L=0.1mH	60	A
		L=0.5mH	32	
Avalanche Energy, Single pulse	$E_{AS}^{(2)}$	L=0.1mH	180	mJ
		L=0.5mH	256	

Thermal Characteristics

Parameter	Symbol	Rating	Unit
Thermal Resistance-Junction to Case	$R_{\theta JC}$	1.2	$^\circ\text{C/W}$
Thermal Resistance-Junction to Ambient	$R_{\theta JA}^{(3)}$	45	$^\circ\text{C/W}$

- ⁽¹⁾ Max. current is limited by junction temperature.
- ⁽²⁾ UIS tested and pulse width are limited by maximum junction temperature 175 $^\circ\text{C}$
- ⁽³⁾ Surface Mounted on 1in² FR-4 board with 1oz.

Electrical Characteristics (T_j = 25°C, unless otherwise specified)

Static Characteristics

Parameter	Symbol	Min.	Typ.	Max.	Unit	Test Conditions
Drain-Source Breakdown Voltage	V _{(BR)DSS}	40	-	-	V	V _{GS} =0V, I _{DS} =250μA
Zero Gate Voltage Drain Current	I _{DSS}	-	-	1	μA	V _{DS} =32V, V _{GS} =0V
Gate Threshold Voltage	V _{GS(th)}	-	3	-	V	V _{DS} =V _{GS} , I _{DS} =250μA
Gate Leakage Current	I _{GSS}	-	-	±100	nA	V _{GS} =±20V, V _{DS} =0V
Drain-Source On-state Resistance	R _{DS(ON)} ⁽⁴⁾	-	0.8	-	mΩ	V _{GS} =10V, I _{DS} =20A
Forward Transconductance	g _{fs}	-	46	-	S	V _{DS} =5V, I _{DS} =10A

Dynamic Characteristics⁽⁵⁾

Parameter	Symbol	Min.	Typ.	Max.	Unit	Test Conditions
Gate Resistance	R _G	-	1	-	Ω	V _{GS} =0V, V _{DS} =0V, Freq.=1MHz
Input Capacitance	C _{iss}	-	4954	-	pF	V _{GS} =0V, V _{DS} =20V, Freq.=1MHz
Output Capacitance	C _{oss}	-	1543	-		
Reverse Transfer Capacitance	C _{rss}	-	98	-		
Turn-on Delay Time	t _{d(ON)}	-	20	-	nS	V _{GS} =10V, V _{DS} =20V, I _D =1A, R _{GEN} =1Ω
Turn-on Rise Time	t _r	-	12	-		
Turn-off Delay Time	t _{d(OFF)}	-	40	-		
Turn-off Fall Time	t _f	-	97	-		

Gate Charge Characteristics

Parameter	Symbol	Min.	Typ.	Max.	Unit	Test Conditions
Total Gate Charge	Q _g	-	64	-	nC	V _{GS} =10V, V _{DS} =20V, I _D =20A
Gate-Source Charge	Q _{gs}	-	26	-		
Gate-Drain Charge	Q _{gd}	-	9.9	-		

Source Drain Diode Characteristics

Parameter	Symbol	Min.	Typ.	Max.	Unit	Test Conditions
Diode Forward Voltage	V _{SD} ⁽⁴⁾	-	0.75	-	V	I _{SD} =10A, V _{GS} =0V
Reverse Recovery Time	t _{rr}	-	61	-	nS	I _F =10A, V _R =20V & dI _F /dt=100A/μs
Reverse Recovery Charge	Q _{rr}	-	52	-	nC	

- ⁽⁴⁾ Pulse test (pulse width ≤ 300μs, duty cycle ≤ 2%).
- ⁽⁵⁾ Guaranteed by design, not subject to production testing.

Electrical Characteristics Diagrams

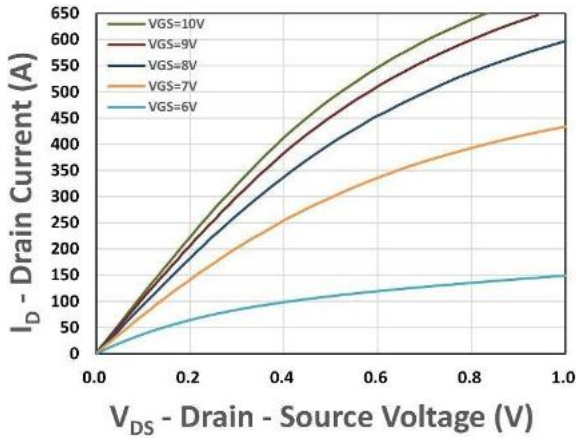

Figure 1. Output Characteristics

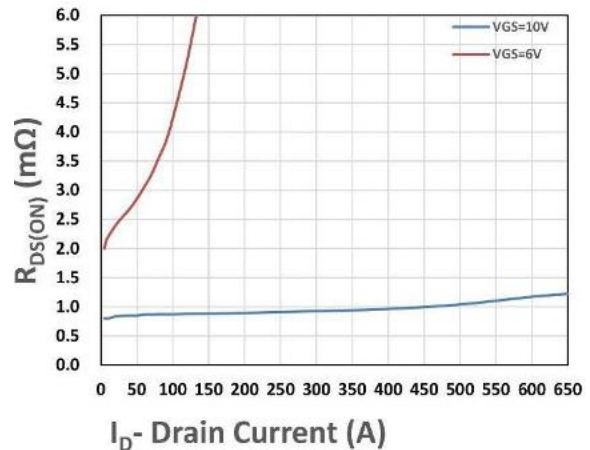

Figure 2. On-Resistance vs. I_D

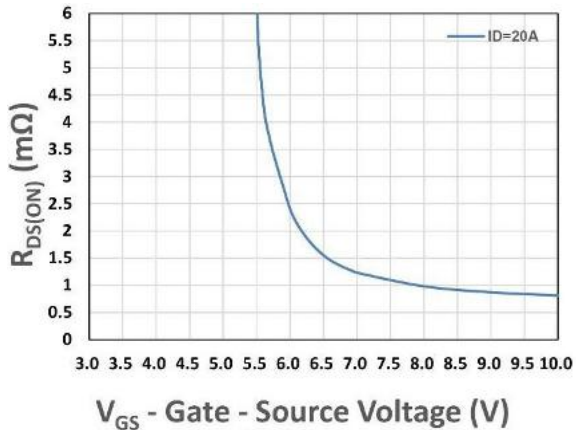

Figure 3. On-Resistance vs. V_{GS}

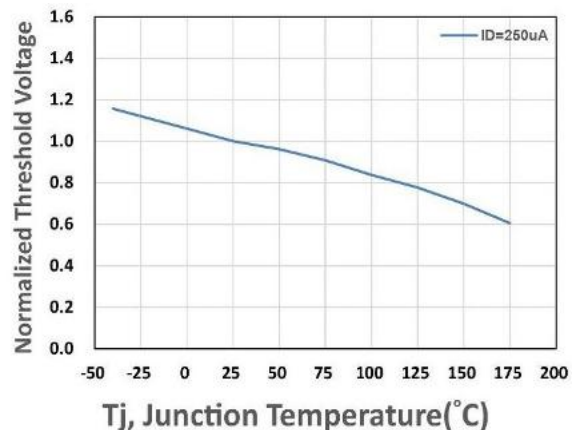

Figure 4. Gate Threshold Voltage

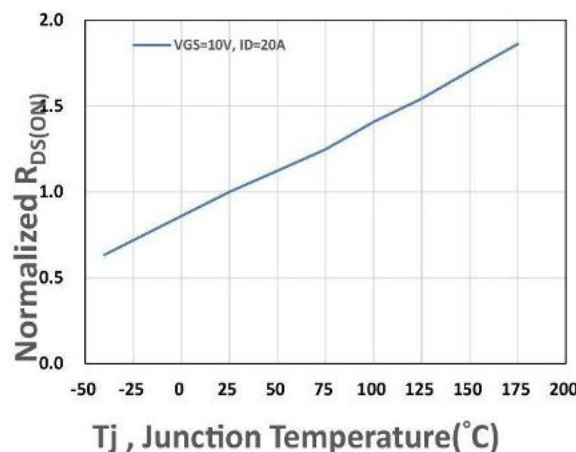

Figure 5. Drain-Source On Resistance

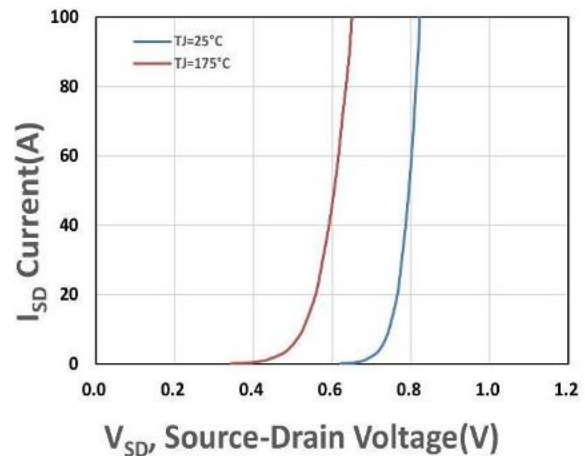
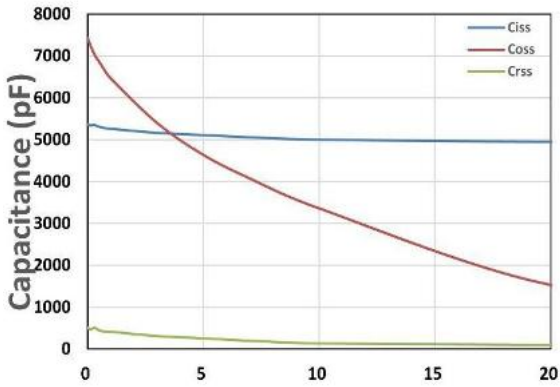
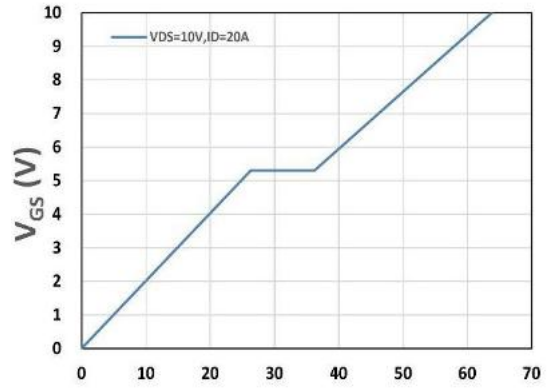

Figure 6. Source-Drain Diode Forward



V_{DS} - Drain - Source Voltage (V)

Figure 7. Capacitance



Q_g , Total Gate Charge (nC)

Figure 8. Gate Charge Characteristics

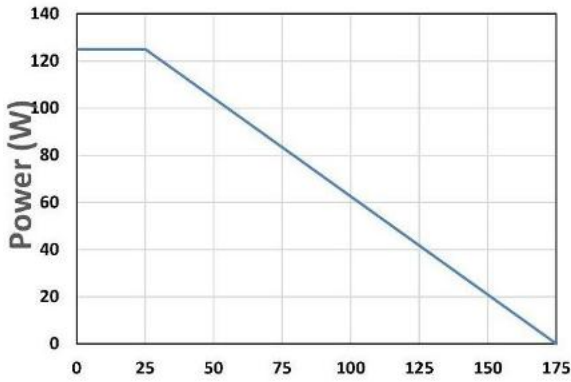

T_c - Case Temperature ($^{\circ}C$)

Figure 9. Power Dissipation

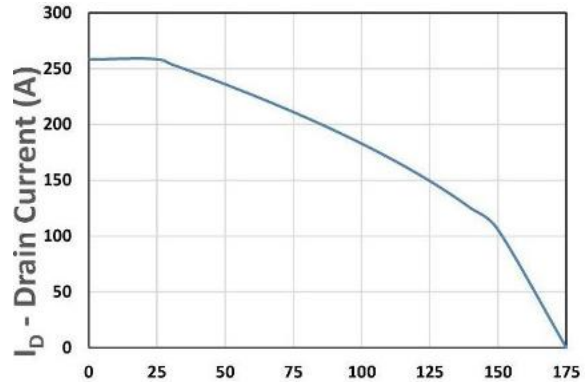

T_c - Case Temperature ($^{\circ}C$)

Figure 10. Drain Current

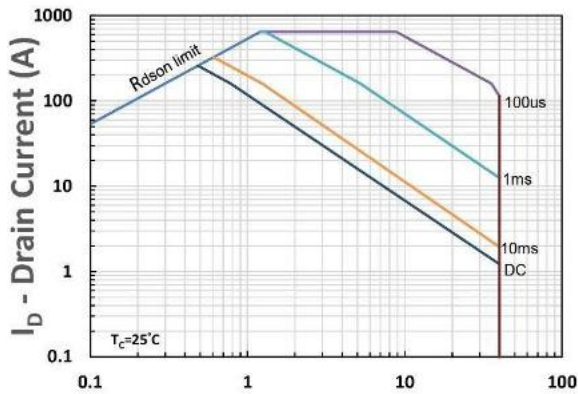

V_{DS} - Drain-Source Voltage (V)

Figure 11. Safe Operating Area

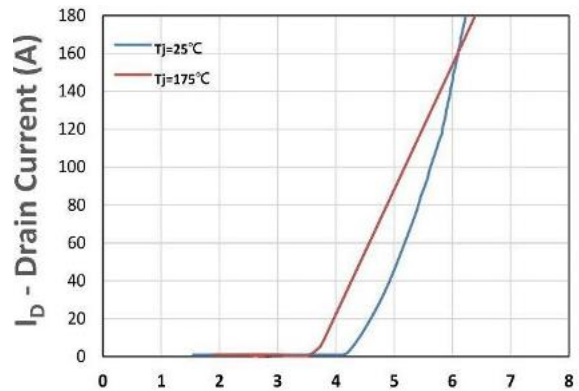

V_{GS} - Gate - Source Voltage (V)

Figure 12. Transfer Characteristics

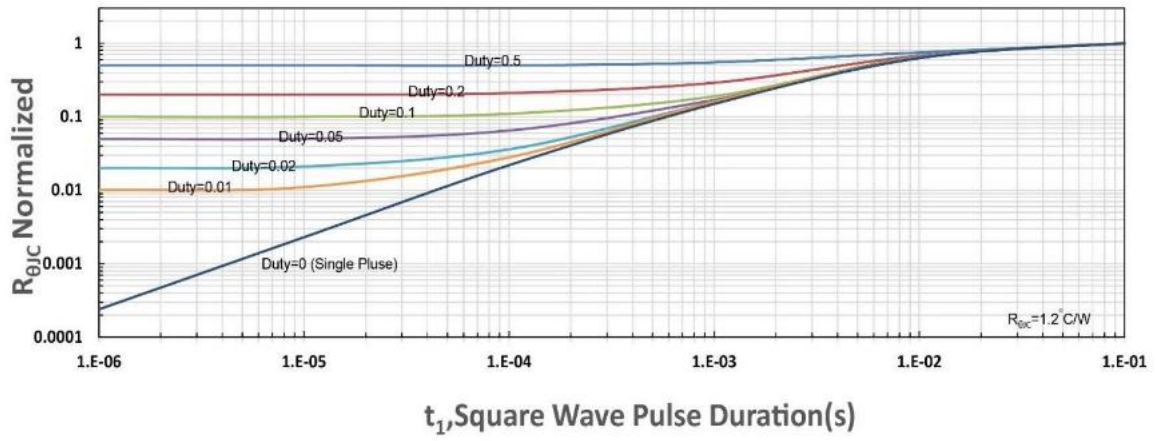
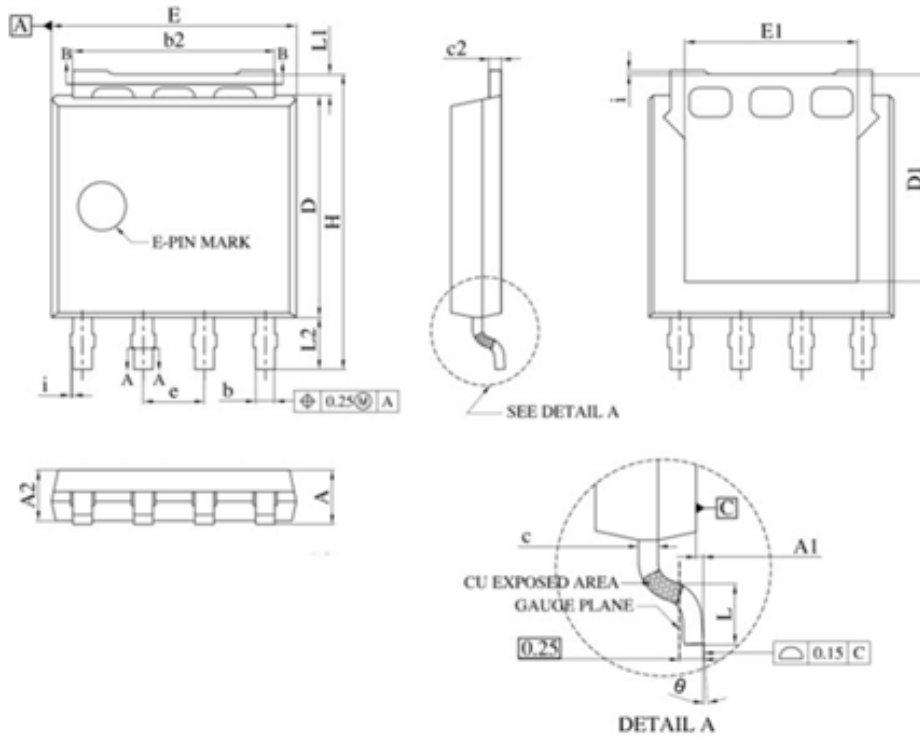

Figure 13. $R_{\theta JC}$ Transient Thermal Impedance

Package Information (LFPAK56)



Outline dimensions in mm

Unit:mm	Min	Typ	Max
A	1.000	-	1.300
A1	0.000	0.075	0.150
A2	0.980	1.050	1.120
b	0.350	0.420	0.500
b2	4.020	4.230	4.410
c	0.190	0.220	0.250
c2	0.240	0.270	0.300
D	4.450	-	4.700
D1	-	-	4.450
E	4.950	-	5.300
E1	3.500	-	3.700
e	1.27 BSC		
H	5.950	-	6.250
i	-	-	0.250
L	0.400	-	0.850
L1	0.270	-	0.570
L2	0.800	-	1.300
θ	0°	-	8°

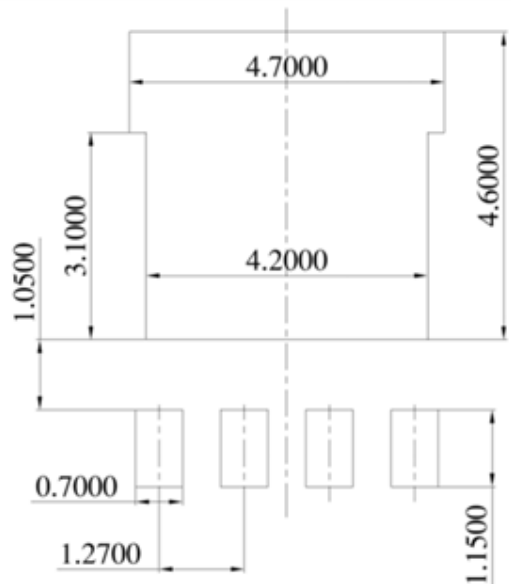

Suggested Pad Layout (Unit:mm)

Disclaimer

The information provided in this datasheet is believed to be accurate and reliable. Errors or omissions are expected. indiaVP Semiconductor Pvt. Ltd. reserves the right to make changes to the product specifications without prior notice. Users should verify the suitability of the product for their specific applications. Please visit our website for the latest datasheet.

Contact Information

indiaVP Semiconductor Pvt. Ltd.

Email: sales@ivpsemi.com

Website: www.ivpsemi.com