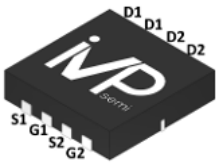
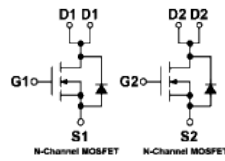

PDFN3.3x3.3(dual)

Symbol

Parameter	Value	Unit
V_{DS}	30	V
$R_{DS(ON)-Max}$	12	m Ω
I_D	28	A

Key Features

- Fast switching speed
- Reliable and Rugged
- ROHS Compliant & Halogen-Free
- 100% UIS Tested

Applications

- DC-DC Converters
- Portable equipment application

Ordering Information

Ordering part Number	Marking code	Package	Form
VPLMDF7108	7108	PDFN3.3x3.3(dual)	Tape & Reel

Absolute Maximum Ratings ($T_J = 25^\circ\text{C}$, unless otherwise specified)

Parameter	Symbol	Rating	Unit
Drain-Source Voltage	V_{DS}	30	V
Gate-Source Voltage	V_{GS}	± 20	V
Maximum Junction Temperature	T_J	150	$^\circ\text{C}$
Storage Temperature Range	T_{STG}	-55 to 150	$^\circ\text{C}$
Pulse Drain Current Tested	$T_C=25^\circ\text{C}$ $I_{DM}^{(1)}$	34	A
Continuous Drain Current	$T_C=25^\circ\text{C}$ I_D	28	A
	$T_C=100^\circ\text{C}$	18	
Maximum Power Dissipation	$T_C=25^\circ\text{C}$ P_D	16	W
	$T_C=100^\circ\text{C}$	6	
Avalanche Current, Single pulse	$L=0.1\text{mH}$ $I_{AS}^{(2)}$	15	A
Avalanche Energy, Single pulse	$L=0.1\text{mH}$ $E_{AS}^{(2)}$	11	mJ

Thermal Characteristics

Parameter	Symbol	Rating	Unit
Thermal Resistance-Junction to Case	Steady State $R_{\theta JC}$	8	$^\circ\text{C/W}$
Thermal Resistance-Junction to Ambient	Steady State $R_{\theta JA}^{(3)}$	105	$^\circ\text{C/W}$

- ⁽¹⁾ Max. current is limited by bonding wire
- ⁽²⁾ UIS tested and pulse width are limited by maximum junction temperature 150°C
- ⁽³⁾ Surface Mounted on 1in^2 FR-4 board with 1oz.

Electrical Characteristics ($T_J = 25^\circ\text{C}$, unless otherwise specified)

Static Characteristics

Parameter	Symbol	Min.	Typ.	Max.	Unit	Test Conditions
Drain-Source Breakdown Voltage	$V_{(BR)DSS}$	30	-	-	V	$V_{GS}=0V, I_{DS}=250\mu A$
Zero Gate Voltage Drain Current	I_{DSS}	-	-	1	μA	$V_{DS}=24V, V_{GS}=0V$
Gate Threshold Voltage	$V_{GS(th)}$	1.1	1.6	2.1	V	$V_{DS}=V_{GS}, I_{DS}=250\mu A$
Gate Leakage Current	I_{GSS}	-	-	± 100	nA	$V_{GS}=\pm 20V, V_{DS}=0V$
Drain-Source On-state Resistance	$R_{DS(ON)}^{(4)}$	-	10	12	m Ω	$V_{GS}=10V, I_{DS}=10A$
		-	12	16		$V_{GS}=4.5V, I_{DS}=6A$
Forward Transconductance	g_{fs}	-	2.5	-	S	$V_{DS}=5V, I_{DS}=5A$

Dynamic Characteristics⁽⁵⁾

Parameter	Symbol	Min.	Typ.	Max.	Unit	Test Conditions
Gate Resistance	R_G	-	3.1	-	Ω	$V_{GS}=0V, V_{DS}=0V,$ Freq.=1MHz
Input Capacitance	C_{iss}	-	871	-	pF	$V_{GS}=0V, V_{DS}=15V,$ Freq.=1MHz
Output Capacitance	C_{oss}	-	110	-		
Reverse Transfer Capacitance	C_{rss}	-	103	-		
Turn-on Delay Time	$t_{d(ON)}$	-	16	-	nS	$V_{GS}=10V, V_{DS}=15V,$ $I_D=1A, R_{GEN}=6\Omega$
Turn-on Rise Time	t_r	-	29	-		
Turn-off Delay Time	$t_{d(OFF)}$	-	30	-		
Turn-off Fall Time	t_f	-	15	-		

Gate Charge Characteristics

Parameter	Symbol	Min.	Typ.	Max.	Unit	Test Conditions
Total Gate Charge	Q_g	-	10.2	-	nC	$V_{GS}=4.5V, V_{DS}=15V$ $I_D=10A$
		-	20.4	-		$V_{GS}=10V, V_{DS}=15V,$ $I_D=10A$
Gate-Source Charge	Q_{gs}	-	2.3	-		
Gate-Drain Charge	Q_{gd}	-	4.7	-		

Source Drain Diode Characteristics

Parameter	Symbol	Min.	Typ.	Max.	Unit	Test Conditions
Diode Forward Voltage	$V_{SD}^{(4)}$	-	0.7	1.1	V	$I_{SD}=1A, V_{GS}=0V$
Reverse Recovery Time	t_{rr}	-	25.3	-	nS	$I_F=1A, V_R=20V$ & $di_F/dt=100A/\mu s$
Reverse Recovery Charge	Q_{rr}	-	10.6	-	nC	

- ⁽⁴⁾ Pulse test (pulse width $\leq 300\mu s$, duty cycle $\leq 2\%$).
- ⁽⁵⁾ Guaranteed by design, not subject to production test

Electrical characteristics diagrams

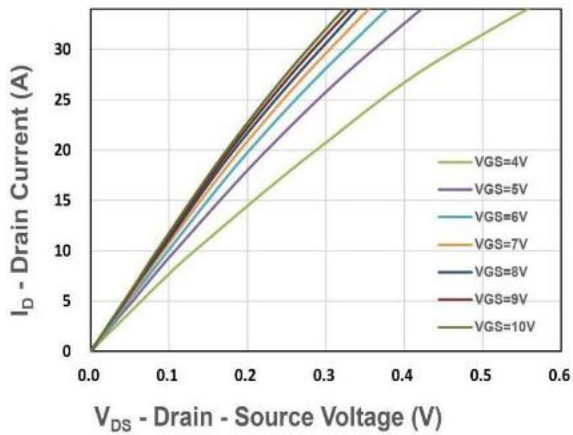

Figure 1. Output Characteristics

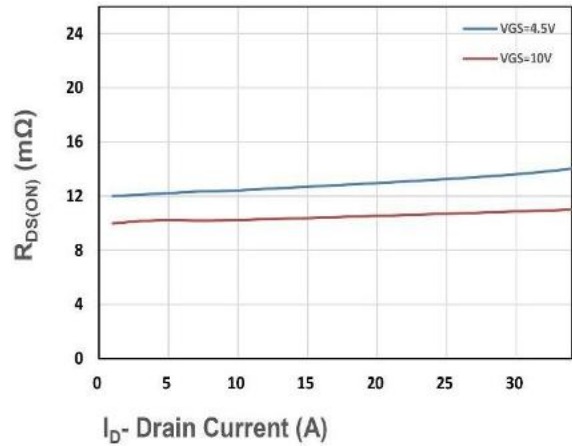

Figure 2. On-Resistance vs. ID

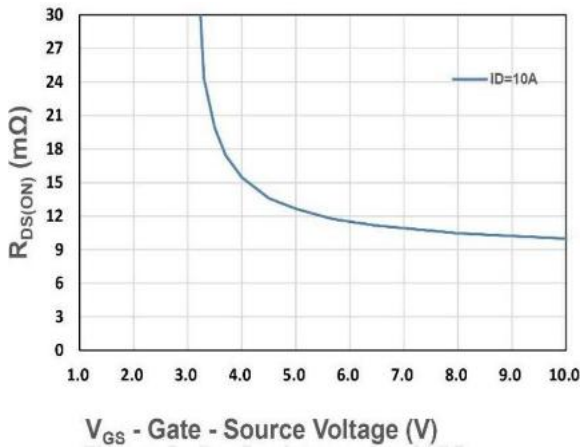

Figure 3. On-Resistance vs. VGS

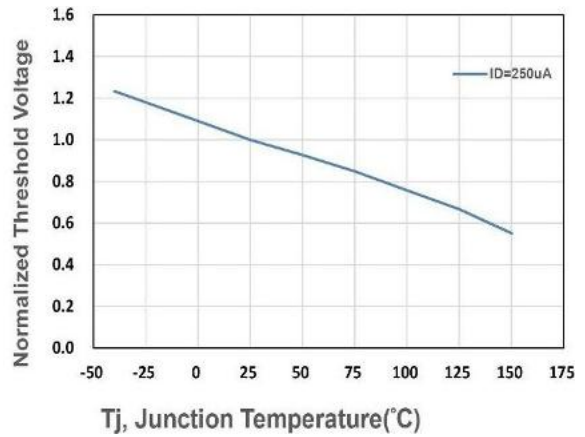

Figure 4. Gate Threshold Voltage

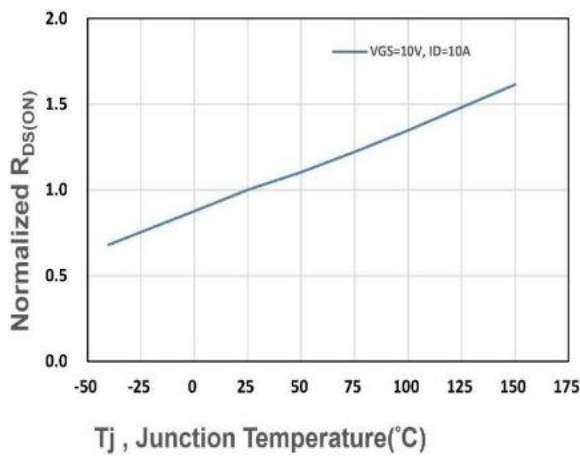

Figure 5. Drain-Source On Resistance

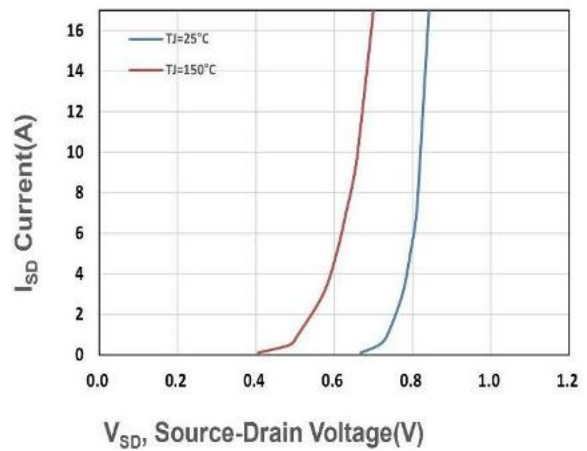
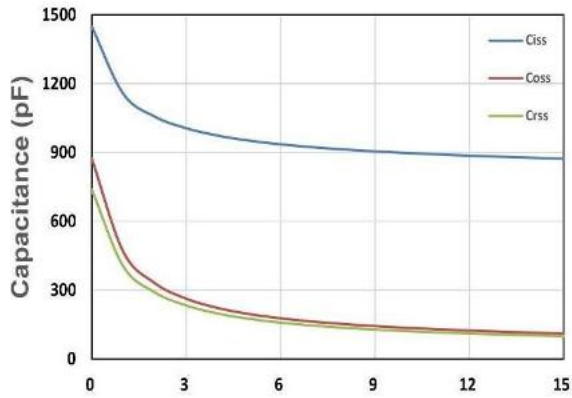
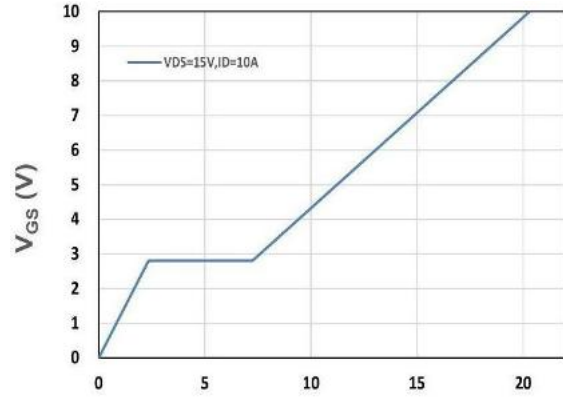

Figure 6. Source-Drain Diode Forward



V_{DS} - Drain - Source Voltage (V)

Figure 7. Capacitance



Q_g , Total Gate Charge (nC)

Figure 8. Gate Charge Characteristics

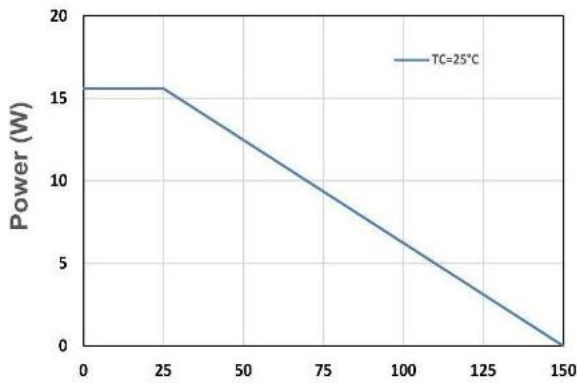

T_j - Junction Temperature ($^{\circ}C$)

Figure 9. Power Dissipation

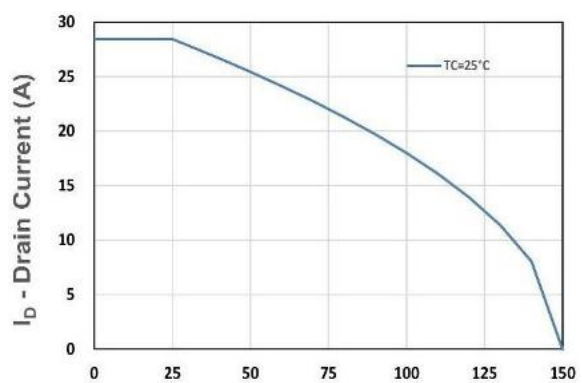

T_j - Junction Temperature ($^{\circ}C$)

Figure 10. Drain Current

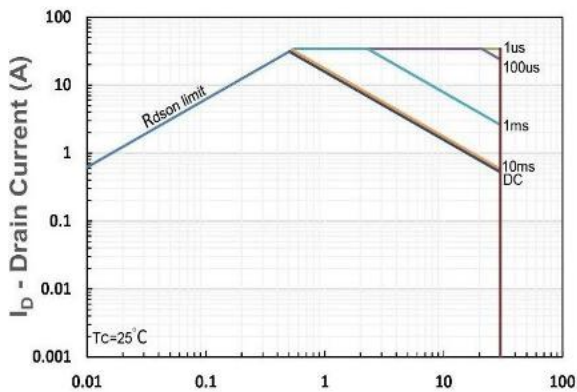

V_{DS} - Drain-Source Voltage (V)

Figure 11. Safe Operating Area

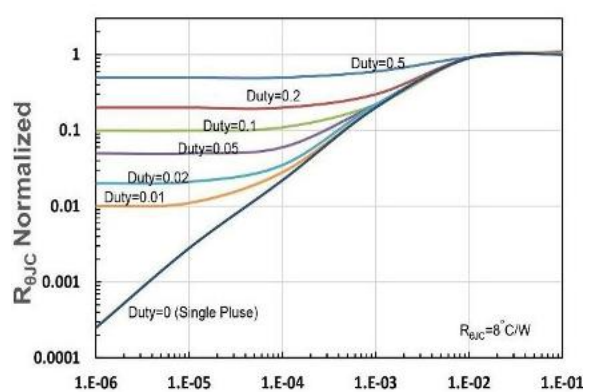

t_i , Square Wave Pulse Duration (s)

Figure 12. $R_{\theta JC}$ Transient Thermal Impedance

Package Information (PDFN3.3x3.3(dual))

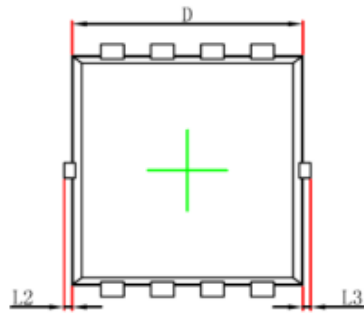

Top View
[顶视图]

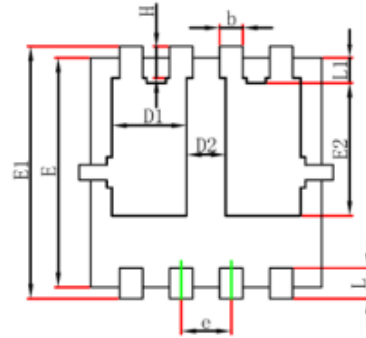

Bottom View
[背视图]

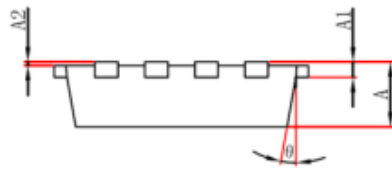

Side View
[侧视图]

Outline Dimensions in mm

Unit:mm	Min	Typ	Max
A	0.650	/	0.850
A1	0.152 REF.		
A2	0~0.05		
D	2.900	/	3.100
D1	0.935	/	1.135
D2	0.280	/	0.480
E	2.900	/	3.100
E1	3.150	/	3.450
E2	1.535	/	1.935
b	0.200	/	0.400
e	0.550	/	0.750
L	0.300	/	0.500
L1	0.180	/	0.480
L2	0~0.1		
L3	0~0.1		
H	0.315	/	0.515
θ	9°	/	13°

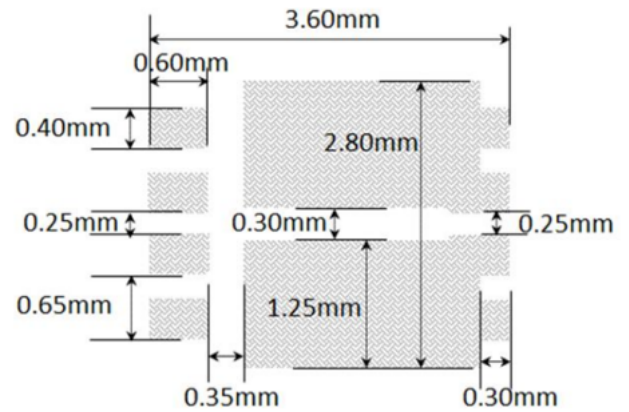

Suggested Pad Layout (Unit:mm)

Disclaimer

The information provided in this datasheet is believed to be accurate and reliable. Errors or omissions are expected. indiaVP Semiconductor Pvt. Ltd. reserves the right to make changes to the product specifications without prior notice. Users should verify the suitability of the product for their specific applications. Please visit our website for the latest datasheet.

Contact Information

indiaVP Semiconductor Pvt. Ltd.

Email: sales@ivpsemi.com

Website: www.ivpsemi.com