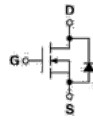

LFPAK56

Symbol

Parameter	Value	Unit
V_{DS}	60	V
$R_{DS(ON)-Max}$	1.5	m Ω
I_D	226	A

Key Features

- Fast switching speed
- Reliable and Rugged
- ROHS Compliant & Halogen-Free
- 100% UIS and Rg Tested
- Moisture Sensitivity Level MSL1

Applications

- DC-to-DC converters
- Switch Mode Power Supply

Ordering Information

Ordering part Number	Marking code	Package	Form
VPLMDF7023	7023	LFPAK56	Tape & Reel

Absolute Maximum Ratings (T_j = 25°C, unless otherwise specified)

Parameter	Symbol	Rating	Unit	
Drain-Source Voltage	V_{DS}	60	V	
Gate-Source Voltage	V_{GS}	+20	V	
Maximum Junction Temperature	T_J	175	°C	
Storage Temperature Range	T_{STG}	-55 to 175	°C	
Diode Continuous Forward Current	I_S	57	A	
Diode Pulse Current	I_{SP}	228 ⁽¹⁾	A	
Pulse Drain Current Tested	I_{DM}	564 ⁽¹⁾	A	
Continuous Drain Current	I_D	$T_C=25^\circ C$	226	A
		$T_C=100^\circ C$	159	
Maximum Power Dissipation	P_D	$T_C=25^\circ C$	167	W
		$T_C=100^\circ C$	83	
Continuous Drain Current	I_D	$T_A=25^\circ C$	32	A
		$T_A=70^\circ C$	27	
Maximum Power Dissipation	P_D	$T_A=25^\circ C$	3.3	W
		$T_A=70^\circ C$	2.3	
Avalanche Current, Single pulse	$I_{AS}^{(2)}$	L=0.1mH	69	A
		L=0.5mH	33	
Avalanche Energy, Single pulse	$E_{AS}^{(2)}$	L=0.1mH	239	mJ
		L=0.5mH	272	

Thermal Characteristics

Parameter	Symbol	Rating	Unit
Thermal Resistance-Junction to Case	$R_{\theta JC}$	0.9	°C/W
Thermal Resistance-Junction to Ambient	$R_{\theta JA}^{(3)}$	45	°C/W

- (1) Max. current is limited by junction temperature.
- (2) UIS tested and pulse width are limited by maximum junction temperature 175°C
- (3) Surface Mounted on 1in² FR-4 board with 1oz.

Electrical Characteristics ($T_j = 25^\circ\text{C}$, unless otherwise specified)

Static Characteristics

Parameter	Symbol	Min.	Typ.	Max.	Unit	Test Conditions
Drain-Source Breakdown Voltage	$V_{(BR)DSS}$	60	-	-	V	$V_{GS}=0V, I_{DS}=250\mu A$
Zero Gate Voltage Drain Current	I_{DSS}	-	-	1	μA	$V_{DS}=48V, V_{GS}=0V$
Gate Threshold Voltage	$V_{GS(th)}$	1.3	1.7	2.3	V	$V_{DS}=V_{GS}, I_{DS}=250\mu A$
Gate Leakage Current	I_{GSS}	-	-	± 100	nA	$V_{GS}=\pm 20V, V_{DS}=0V$
Drain-Source On-state Resistance	$R_{DS(ON)}^{(4)}$	-	1.2	1.5	m Ω	$V_{GS}=10V, I_{DS}=20A$
		-	1.6	2.2		$V_{GS}=4.5V, I_{DS}=15A$
Forward Transconductance	g_{fs}	-	53	-	S	$V_{DS}=5V, I_{DS}=10A$

Dynamic Characteristics⁽⁵⁾

Parameter	Symbol	Min.	Typ.	Max.	Unit	Test Conditions
Gate Resistance	R_G	-	0.5	-	Ω	$V_{GS}=0V, V_{DS}=0V,$ Freq.=1MHz
Input Capacitance	C_{iss}	-	6567	-	pF	$V_{GS}=0V, V_{DS}=30V,$ Freq.=1MHz
Output Capacitance	C_{oss}	-	825	-		
Reverse Transfer Capacitance	C_{rss}	-	116	-		
Turn-on Delay Time	$t_{d(ON)}$	-	17	-	nS	$V_{GS}=10V, V_{DS}=30V,$ $I_D=1A, R_{GEN}=1\Omega$
Turn-on Rise Time	t_r	-	9	-		
Turn-off Delay Time	$t_{d(OFF)}$	-	57	-		
Turn-off Fall Time	t_f	-	72	-		

Gate Charge Characteristics

Parameter	Symbol	Min.	Typ.	Max.	Unit	Test Conditions
Total Gate Charge	Q_g	-	47	-	nC	$V_{GS}=4.5V, V_{DS}=30V,$ $I_D=20A$
		-	94	-		$V_{GS}=10V, V_{DS}=30V,$ $I_D=20A$
Gate-Source Charge	Q_{gs}	-	19	-		
Gate-Drain Charge	Q_{gd}	-	15	-		

Source Drain Diode Characteristics

Parameter	Symbol	Min.	Typ.	Max.	Unit	Test Conditions
Diode Forward Voltage	$V_{SD}^{(4)}$	-	0.7	1.1	V	$I_{SD}=10A, V_{GS}=0V$
Reverse Recovery Time	t_{rr}	-	57	-	nS	$I_F=10A, V_R=30V$ & $di_F/dt=100A/\mu s$
Reverse Recovery Charge	Q_{rr}	-	101	-	nC	

- ⁽⁴⁾ Pulse test (pulse width $\leq 300\mu s$, duty cycle $\leq 2\%$).
- ⁽⁵⁾ Guaranteed by design, not subject to production test

Electrical Characteristics Diagrams

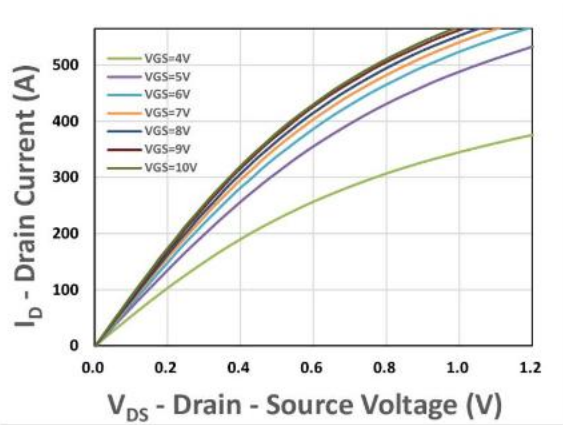

Figure 1. Output Characteristics

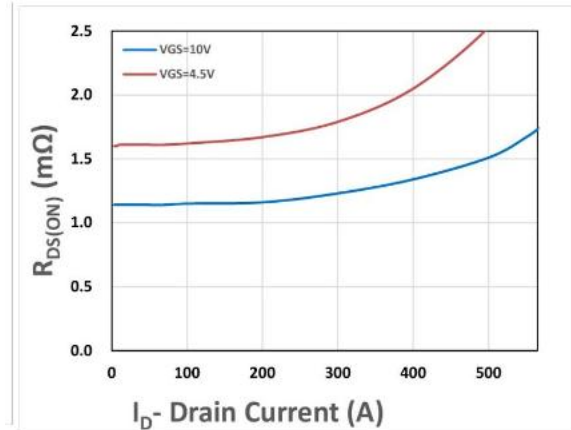

Figure 2. On-Resistance vs. ID

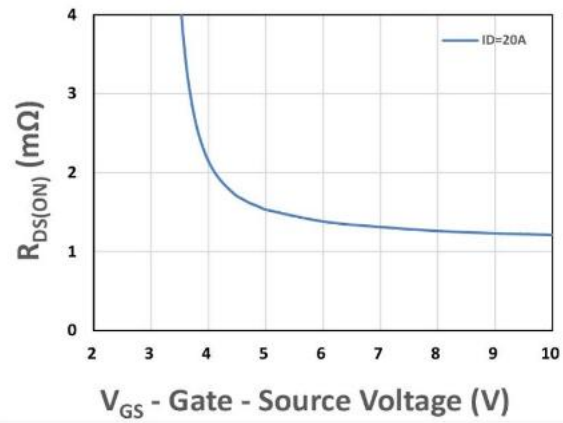

Figure 3. On-Resistance vs. VGS

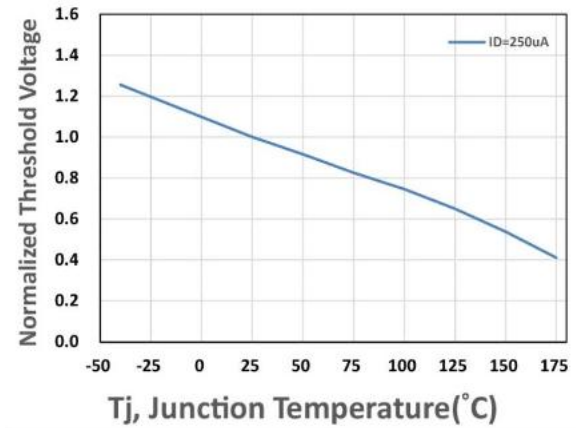

Figure 4. Gate Threshold Voltage

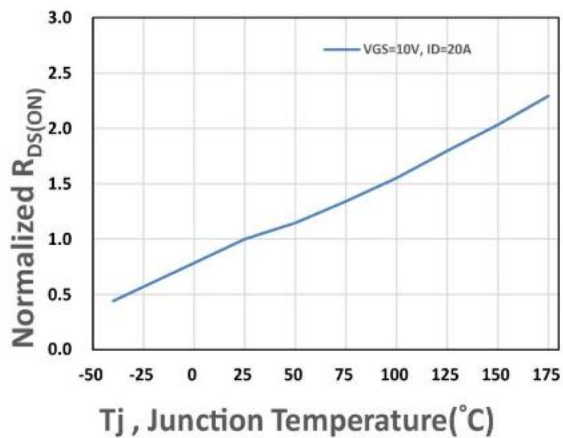

Figure 5. Drain-Source On Resistance

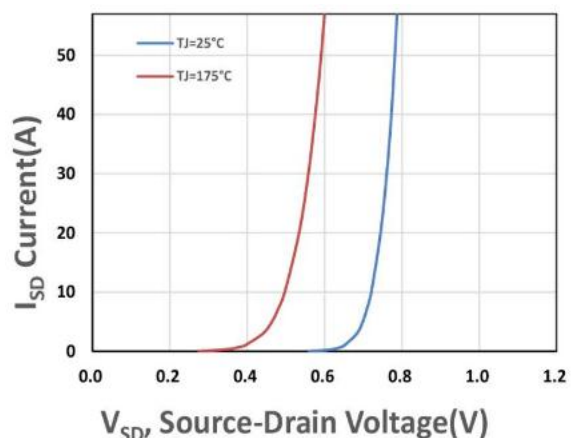

Figure 6. Source-Drain Diode Forward

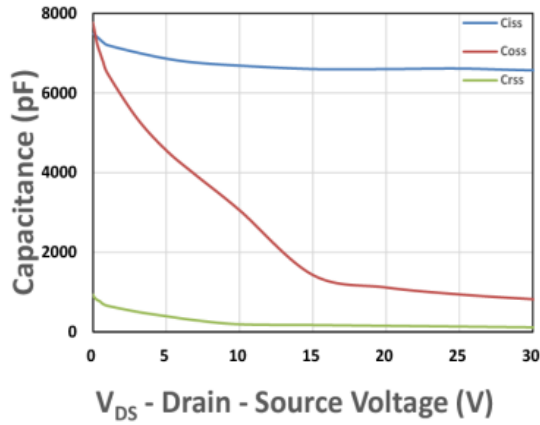

Figure 7. Capacitance

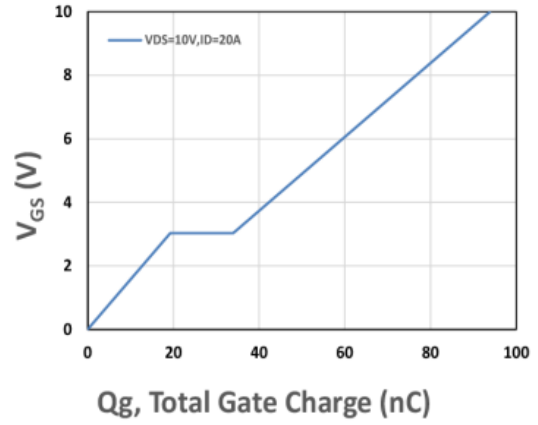

Figure 8. Gate Charge Characteristics

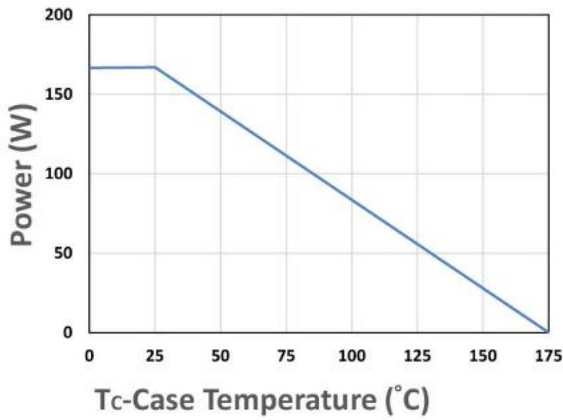

Figure 9. Power Dissipation

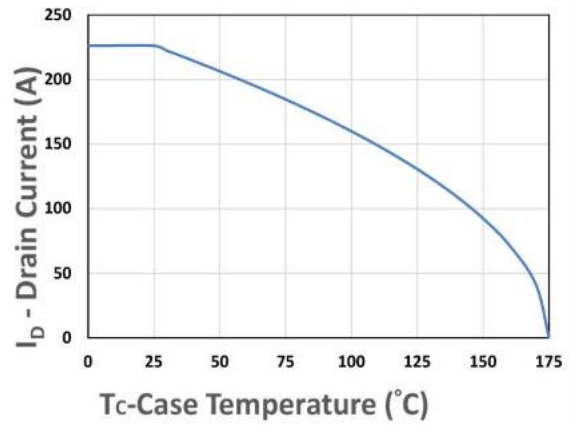

Figure 10. Drain Current

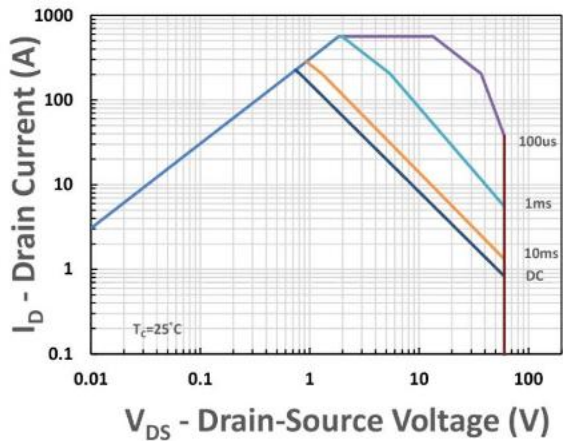

Figure 11. Safe Operating Area

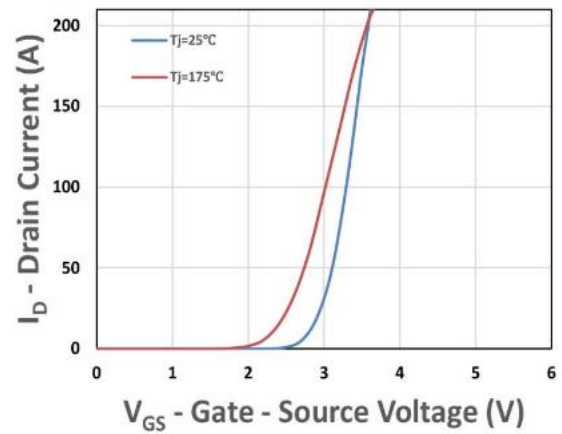

Figure 12. Transfer Characteristics

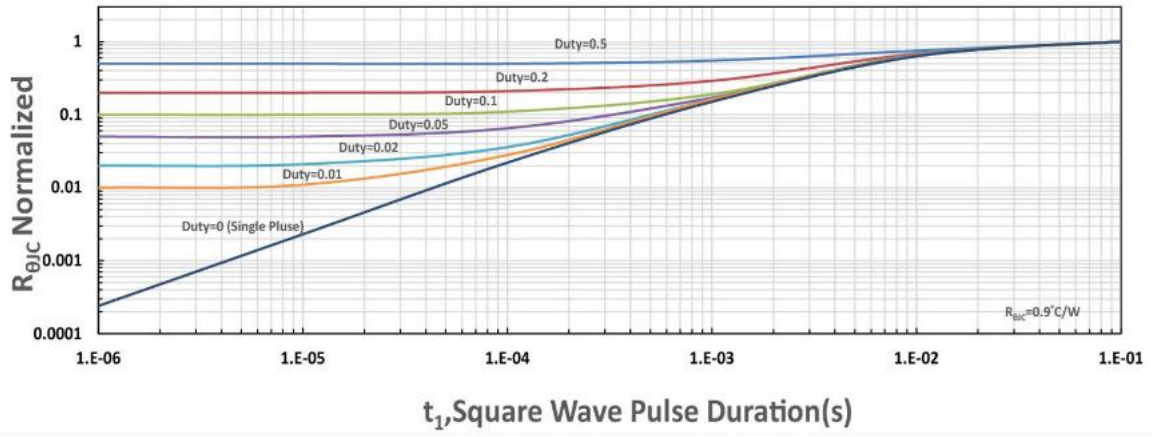
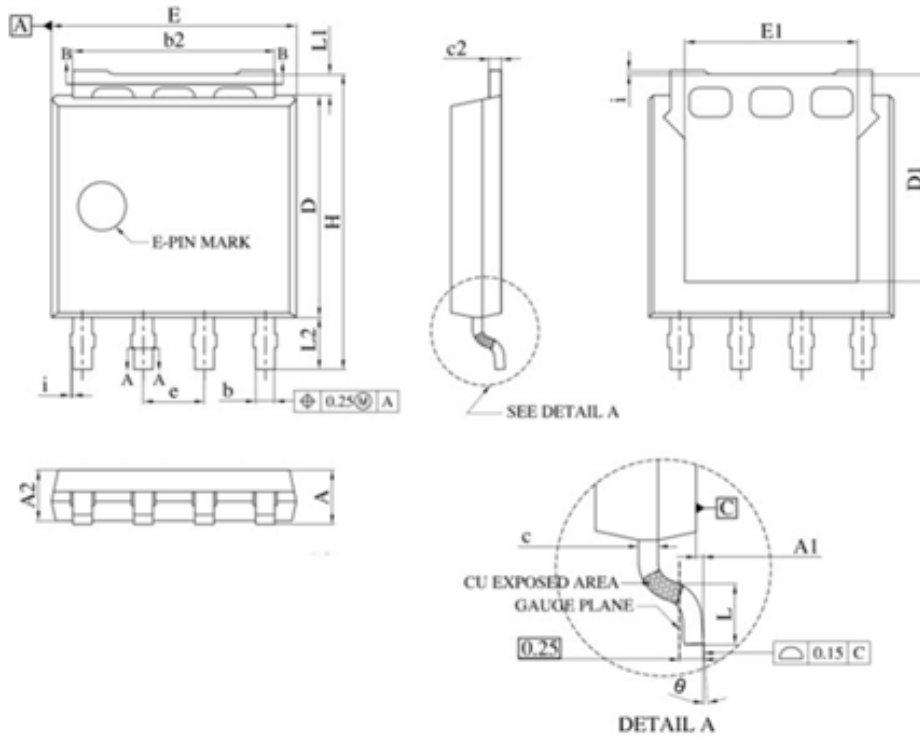

Figure 13. $R_{\theta JC}$ Transient Thermal Impedance

Package Information (LFPAK56)



Outline dimensions in mm

Unit:mm	Min	Typ	Max
A	1.000	-	1.300
A1	0.000	0.075	0.150
A2	0.980	1.050	1.120
b	0.350	0.420	0.500
b2	4.020	4.230	4.410
c	0.190	0.220	0.250
c2	0.240	0.270	0.300
D	4.450	-	4.700
D1	-	-	4.450
E	4.950	-	5.300
E1	3.500	-	3.700
e	1.27 BSC		
H	5.950	-	6.250
i	-	-	0.250
L	0.400	-	0.850
L1	0.270	-	0.570
L2	0.800	-	1.300
θ	0°	-	8°

Suggested Pad Layout(Unit:mm)

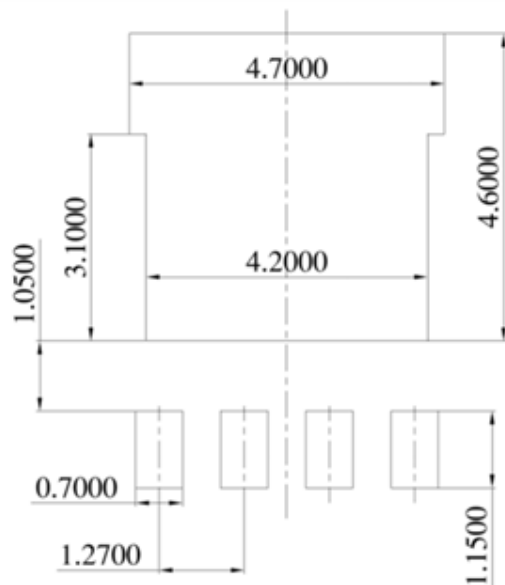

Suggested Pad Layout (Unit:mm)

Disclaimer

The information provided in this datasheet is believed to be accurate and reliable. Errors or omissions are expected. indiaVP Semiconductor Pvt. Ltd. reserves the right to make changes to the product specifications without prior notice. Users should verify the suitability of the product for their specific applications. Please visit our website for the latest datasheet.

Contact Information

indiaVP Semiconductor Pvt. Ltd.

Email: sales@ivpsemi.com

Website: www.ivpsemi.com